

# AEM21 port protection - concept

2 / 23  
[01]

- Water cooled front-plate covering most of port.
- Small cut-out to allow necessary diagnostic view.

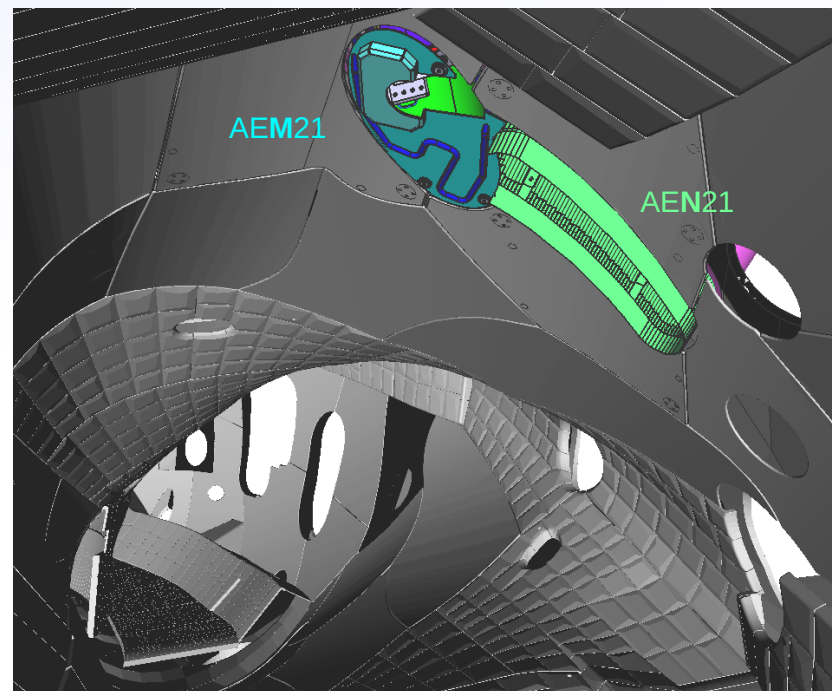
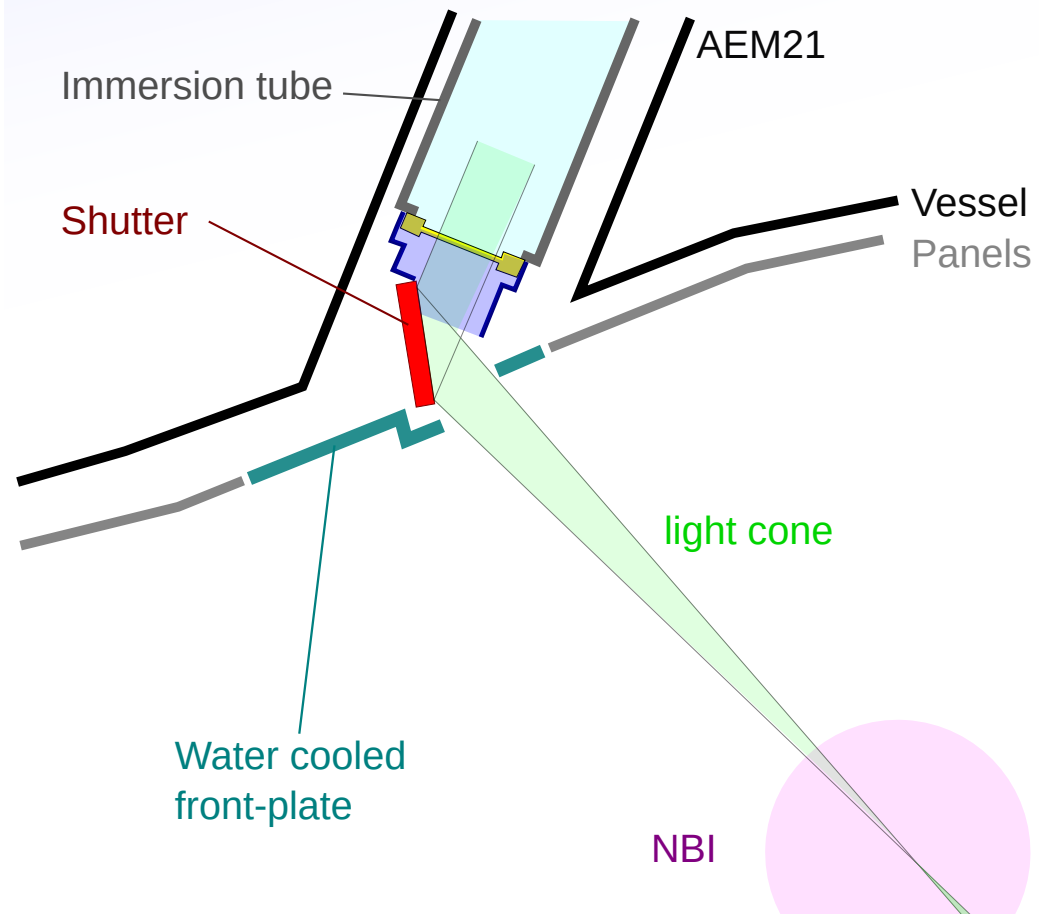

View including neighbouring AEN21 Portliner,

# AEM21 port protection - port shield

3 / 23  
[03]

Back surface 'port shield' to protect port wall, 'zwickel' and welding seams together with AEN21 port-liner.

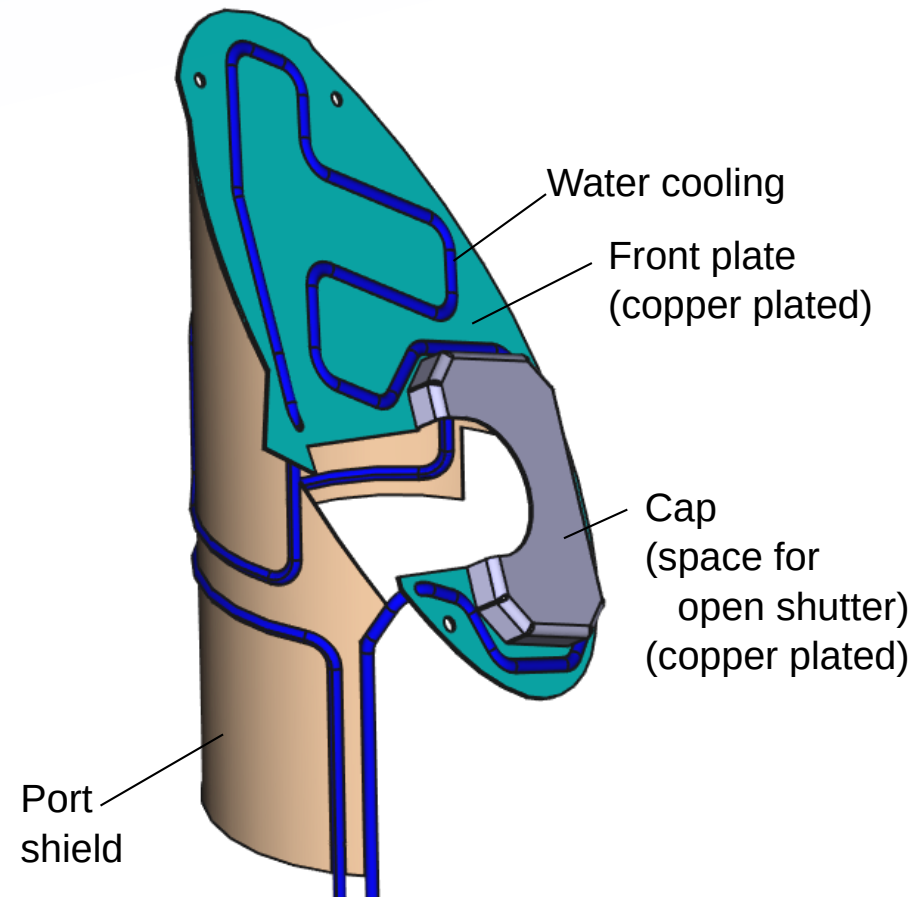
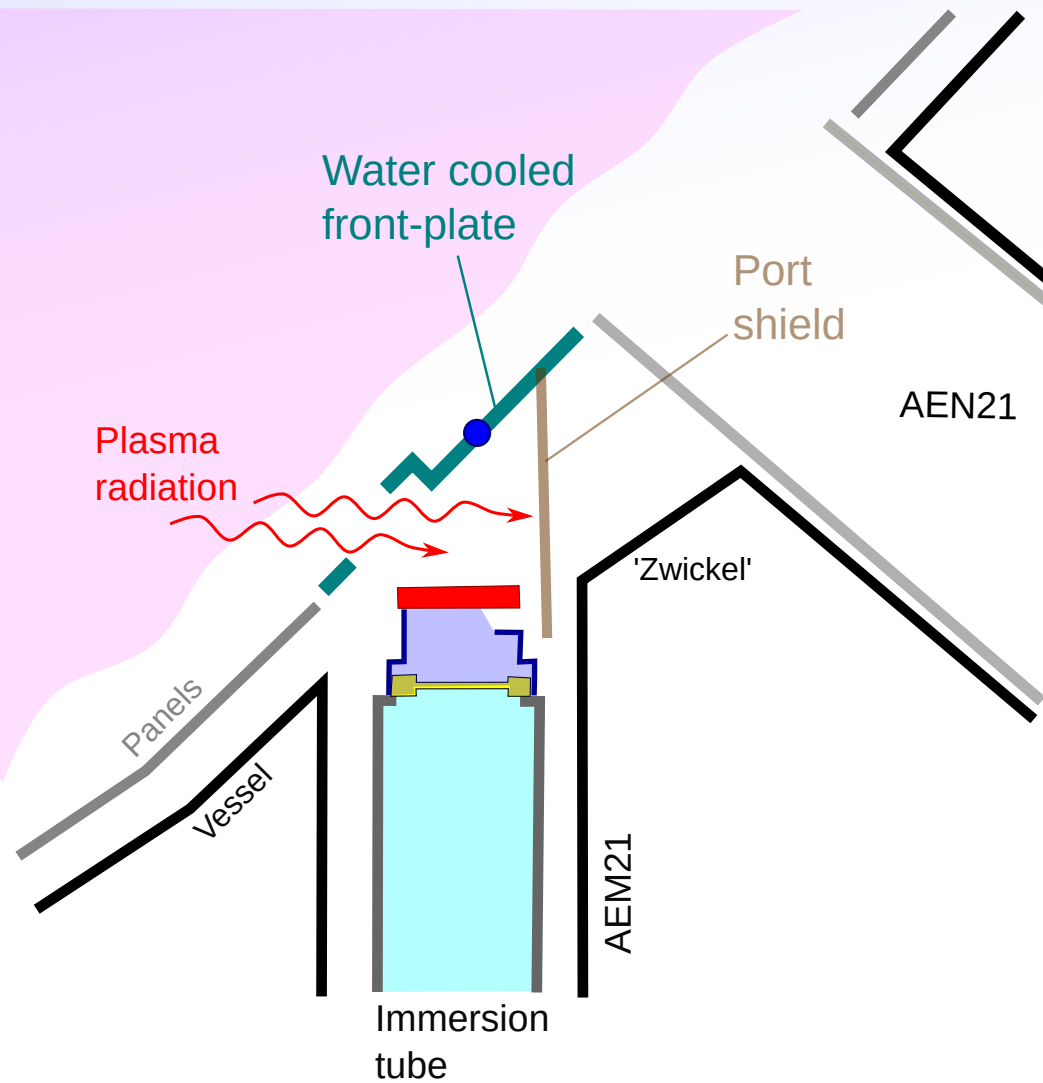

# AEM21 port protection - construction

Port protection assembled from 3 distinct parts:

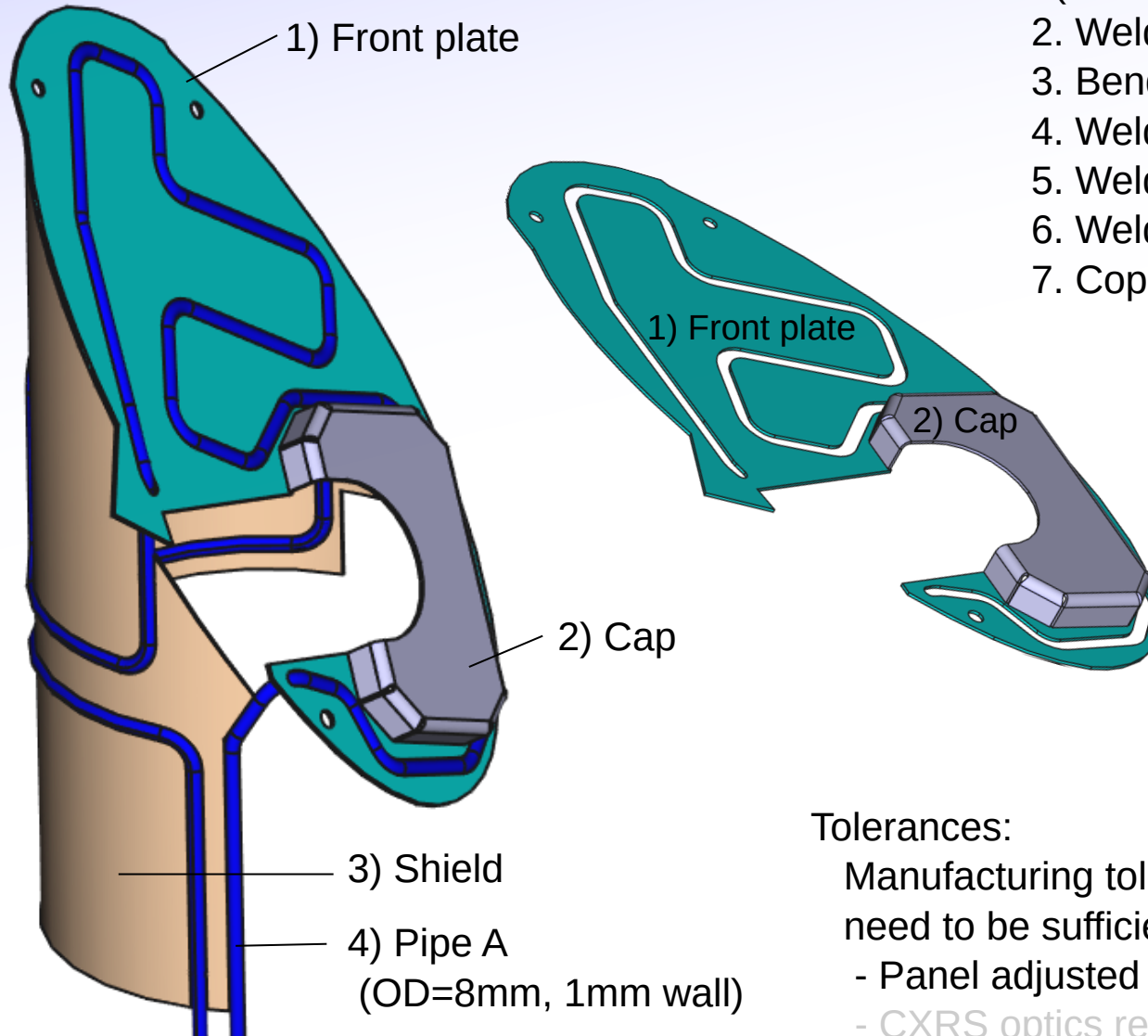

1. Manufacture front plate, cap, shield  
(+ Manufacture aluminium dummy FP)
2. Weld cap to front plate
3. Bend pipe sections
4. Weld together pipe sections
5. Weld pipe into front plate
6. Weld shield parts to pipe
7. Copper plating

### Tolerances:

- Manufacturing tolerances will not be high, but only need to be sufficient to fit shield in port without stress.
- Panel adjusted to other panels during installation
  - CXRS optics require only ~ +/- 5mm.
  - Manufacturing tolerances  $\pm 1$ mm in TS: 1-QSK-S0007



# AEM21 port protection - copper plating

Copper plating to increase thermal conductivity to SS cooling pipes. Apply copper to back of front plate and cap and back side of shield.

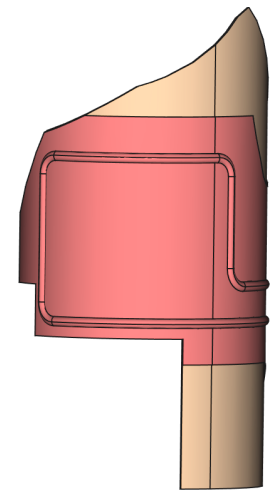
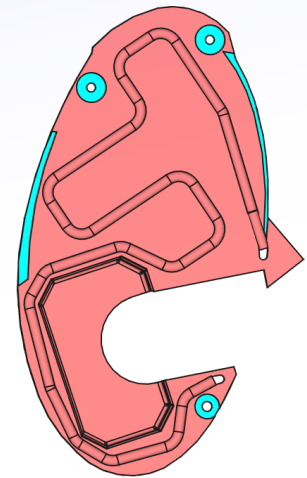
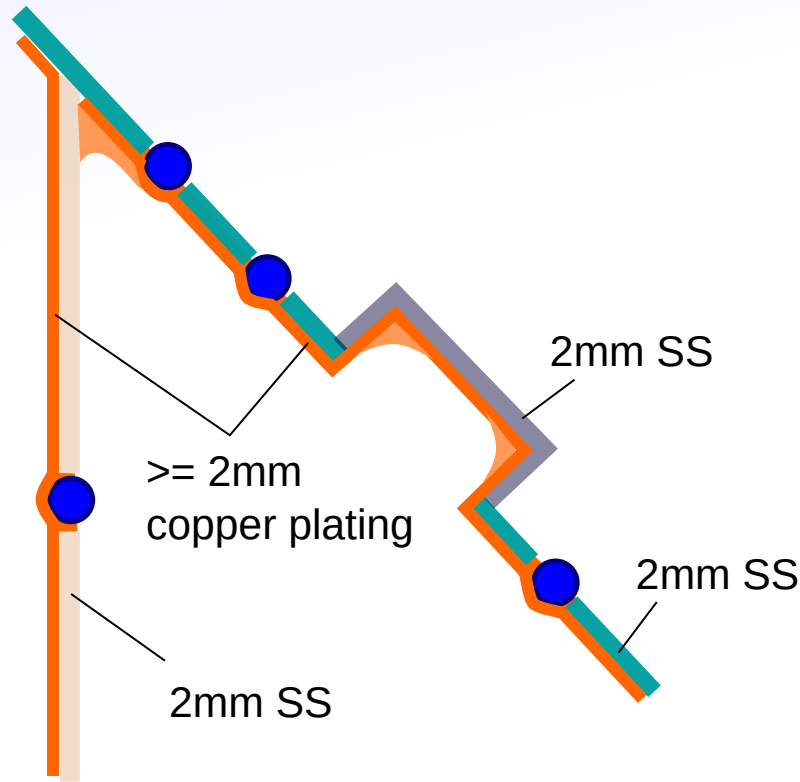
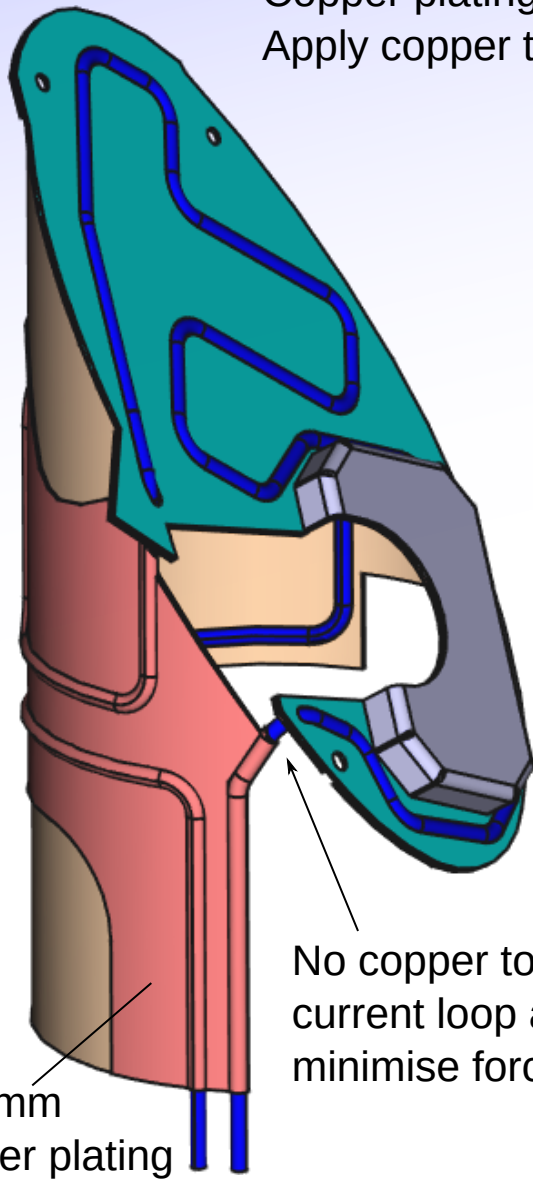

Copper plating expertise by Galvano-T.

- CTS Plugin for ECRH - (Delivered)
- AEA21 front plate (In discussion)
- Initial assessment by Galvano-T as feasible but copper thickness may vary significantly as difficult to work in corners.

# AEM21 port protection - pipes

- Space for water cooling pipes very limited.
- Contact of immersion tube with pipes in LC2 (Ausheizen) --> stress on pipes join to panel.
- Solution:
  - 1) Use narrower pipes than usual (8mm, 1mm wall).
  - 2) Pipes on side of tube with narrowest as-built gap.  
Tube moves away in other load cases.

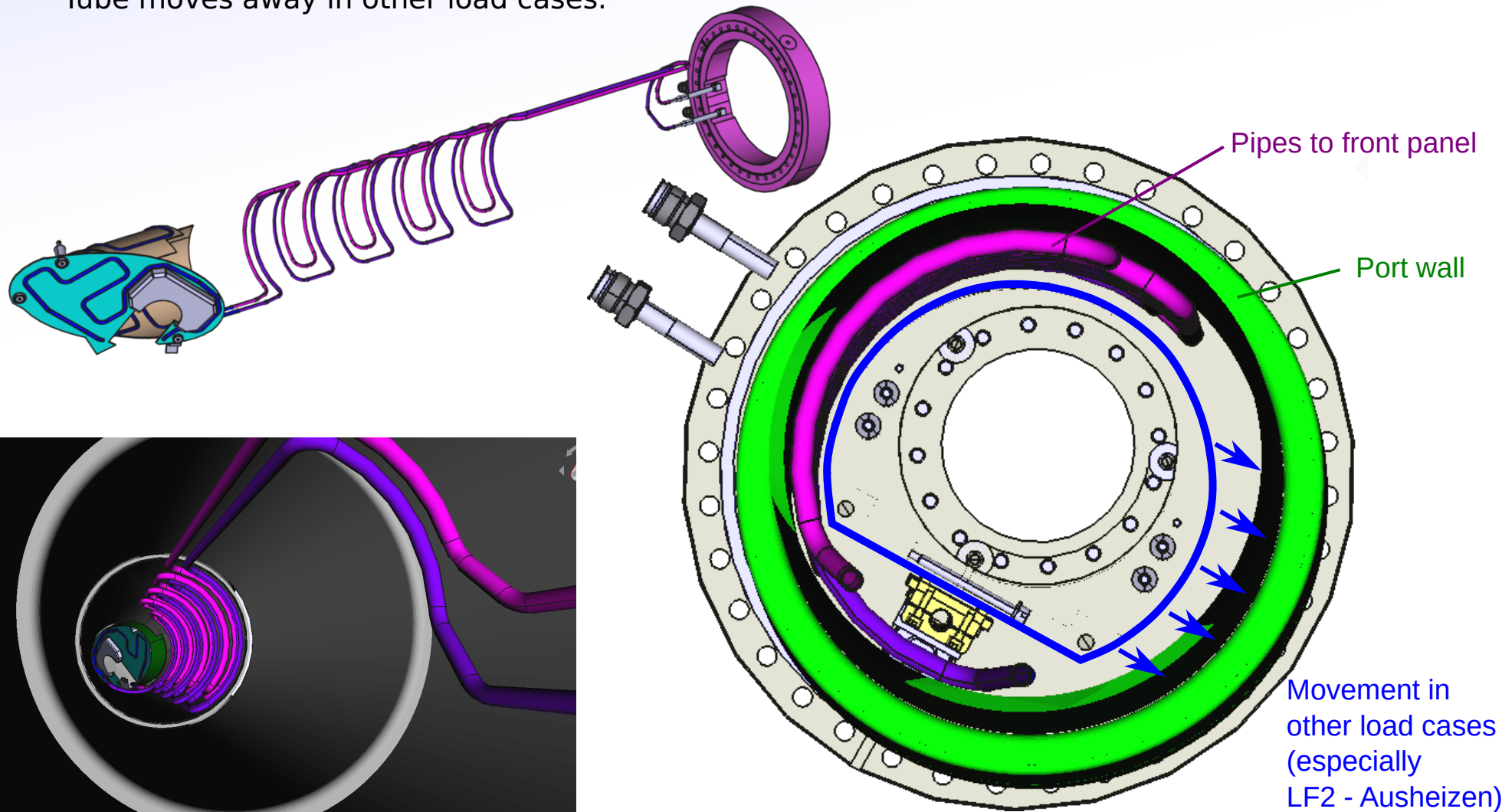



## AEM21 port protection - pipes

- Space for water cooling pipes very limited.
- Contact of immersion tube with pipes in LC2 (Ausheizen) --> stress on pipes join to panel.
- Solution:

**1) Use narrower pipes than usual (8mm, 1mm wall).**

2) Pipes on side of tube with narrowest as-built gap.

Tube moves away in other load cases.

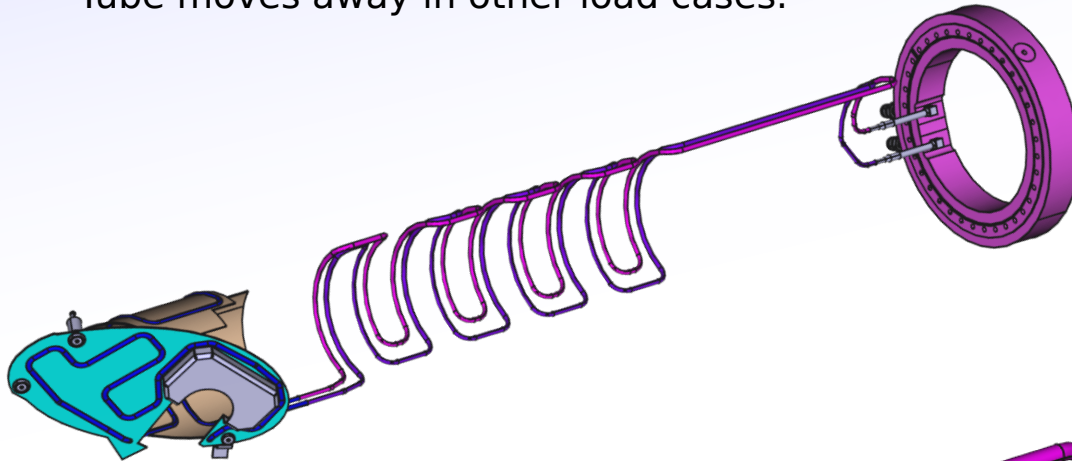

Welding tools (to passing) only  
available for 12mm pipes,  
so need taper from 12mm to 8mm:

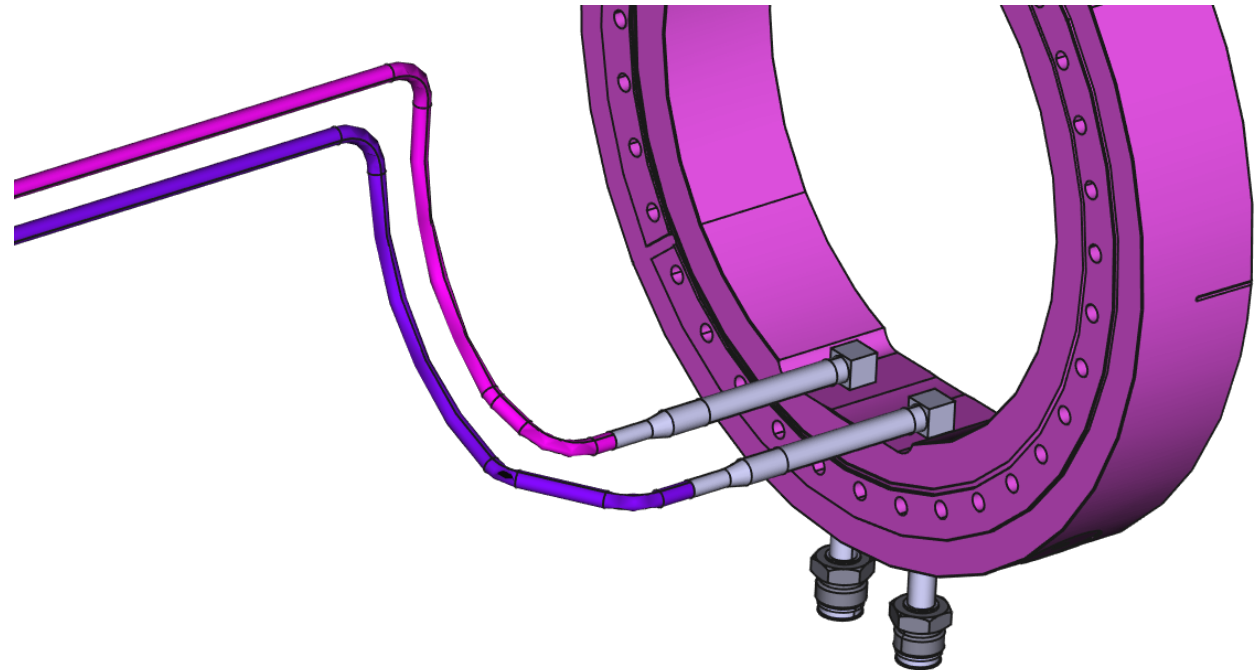

## AEM21 port protection - Mounts

- Front plate mounted on two bolts and one metal bracket:
- Bolts and bracket to be installed before re-installation of surrounding panels (~Feb 21)
- Bolts and brackets provided by E3.
- Precise positions/vectors to be provided to AS by E3.
  
- Manufacture an aluminium 'dummy' front plate to assist/test mounts.

Head-on view (looking up at port from inside vessel):

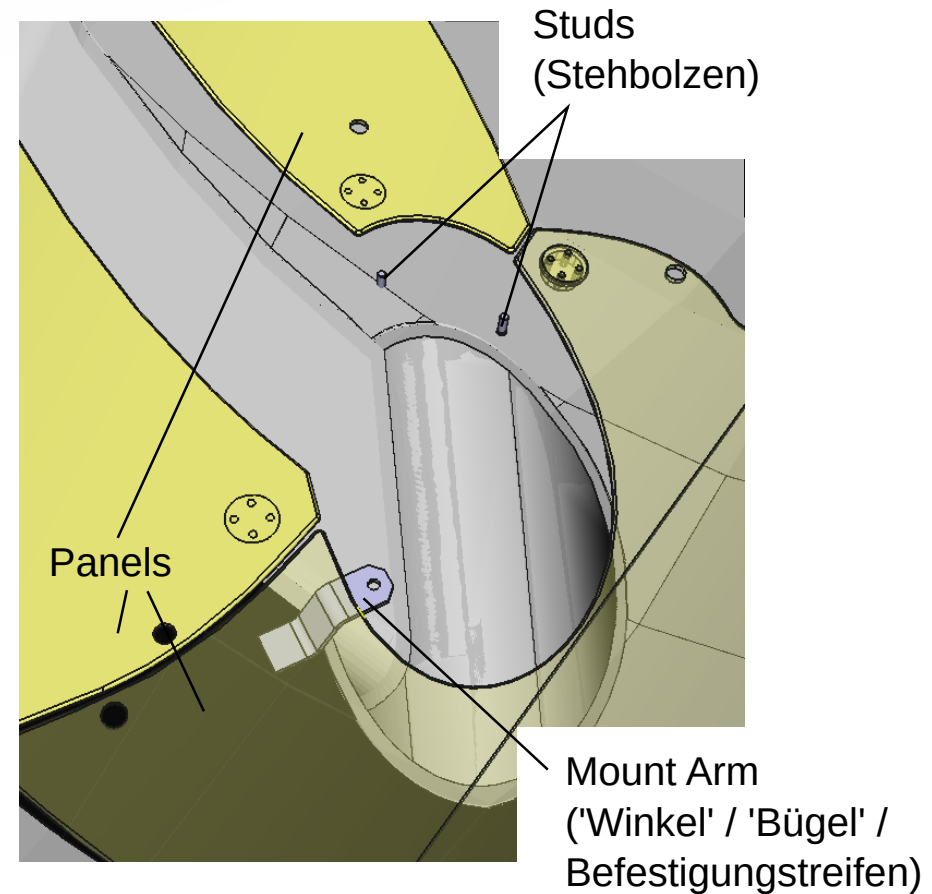
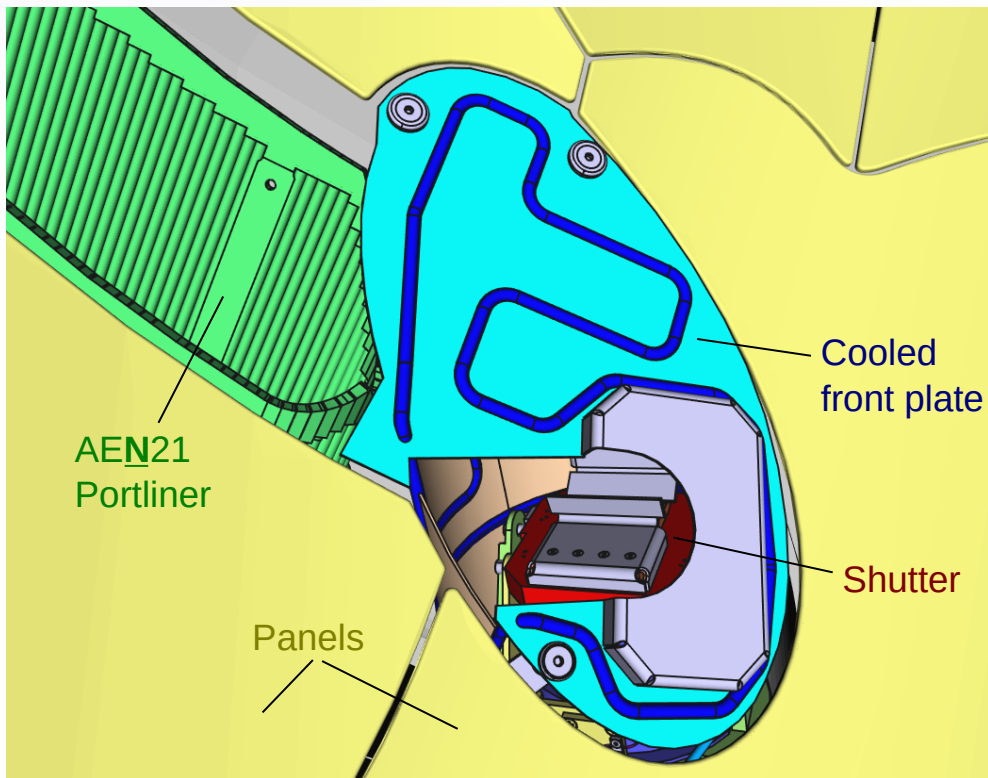

# AEM21 port protection - Mounts check

8 / 23  
[10]

- Check position of bolts relative to edges of port tube:

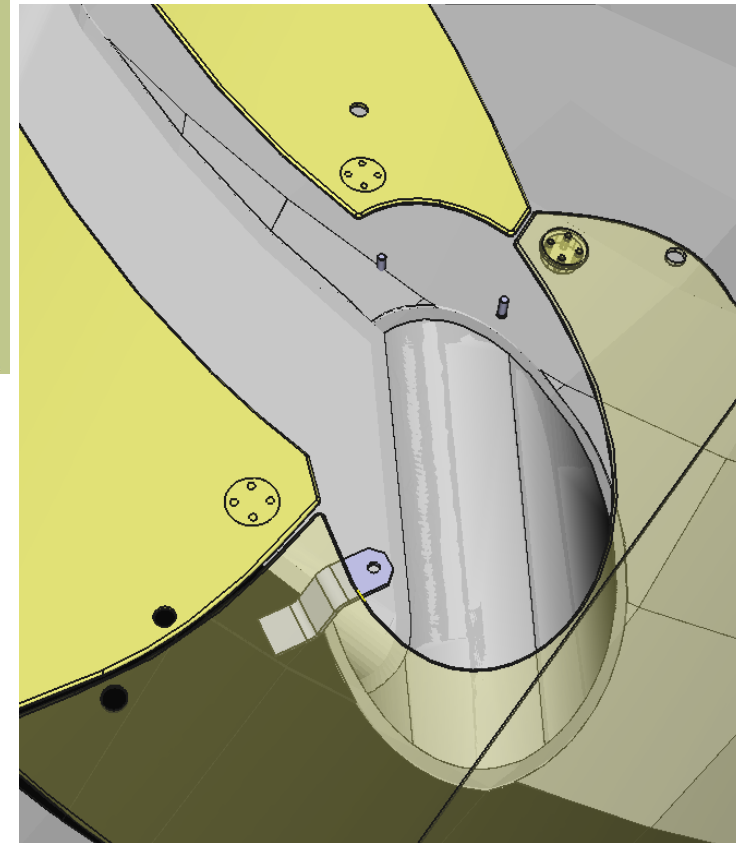
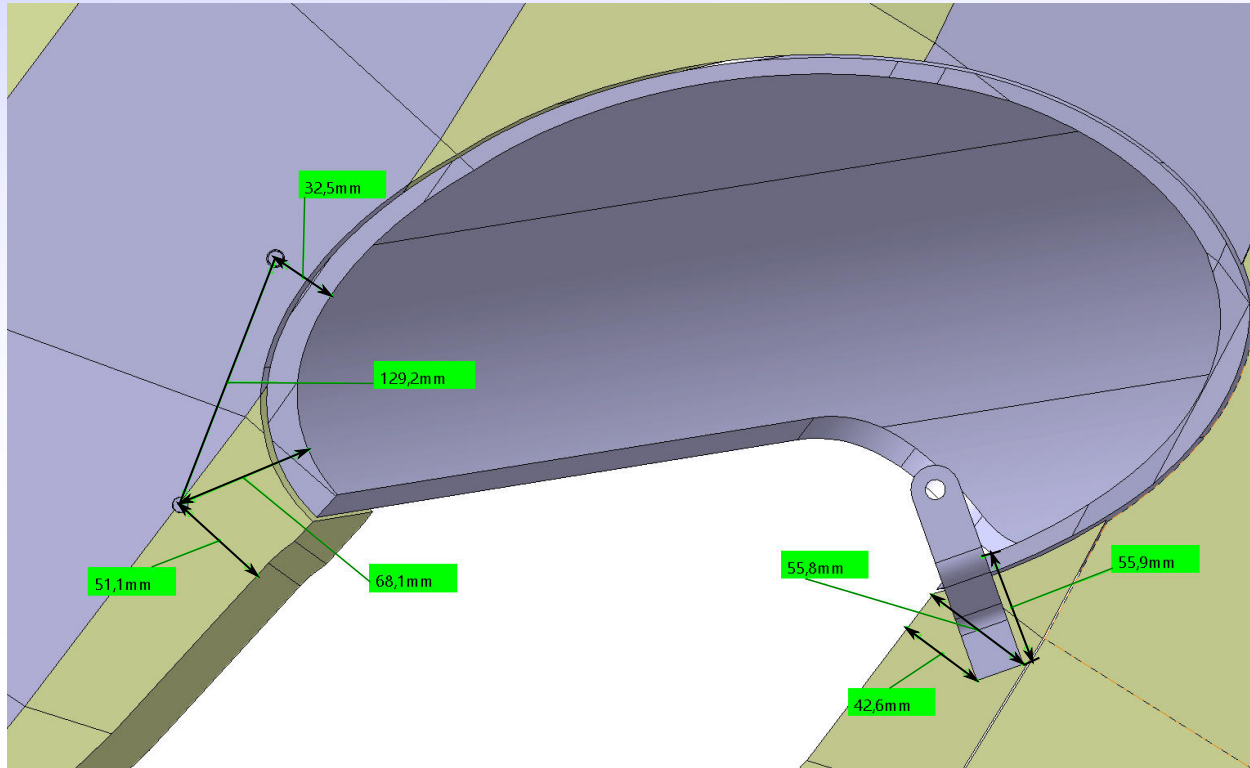



# AEM21 port protection - Installation

- Installation in stages, due to length of pipes:

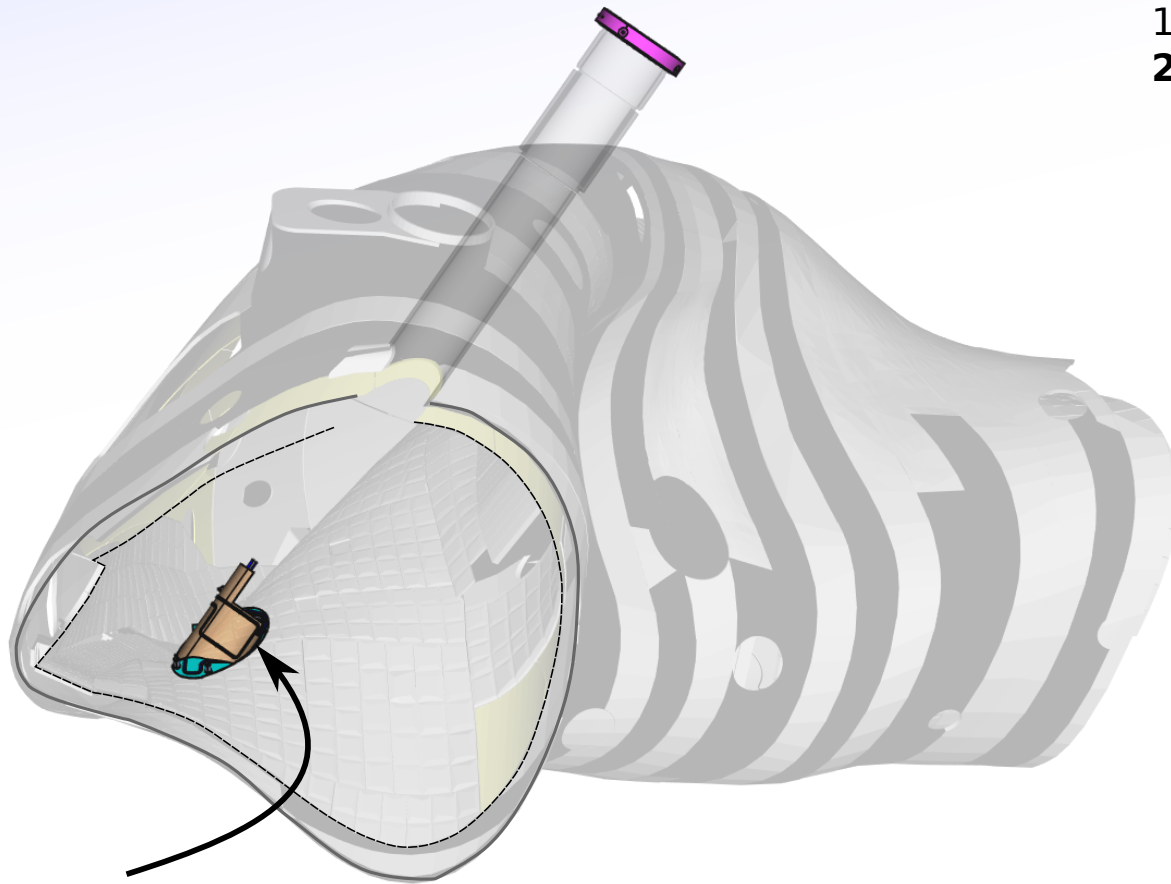

1) Install passring.

**2) Bring port protection into vessel**

## AEM21 port protection - Installation

10 / 23  
[12]

- Installation in stages, due to length of pipes:

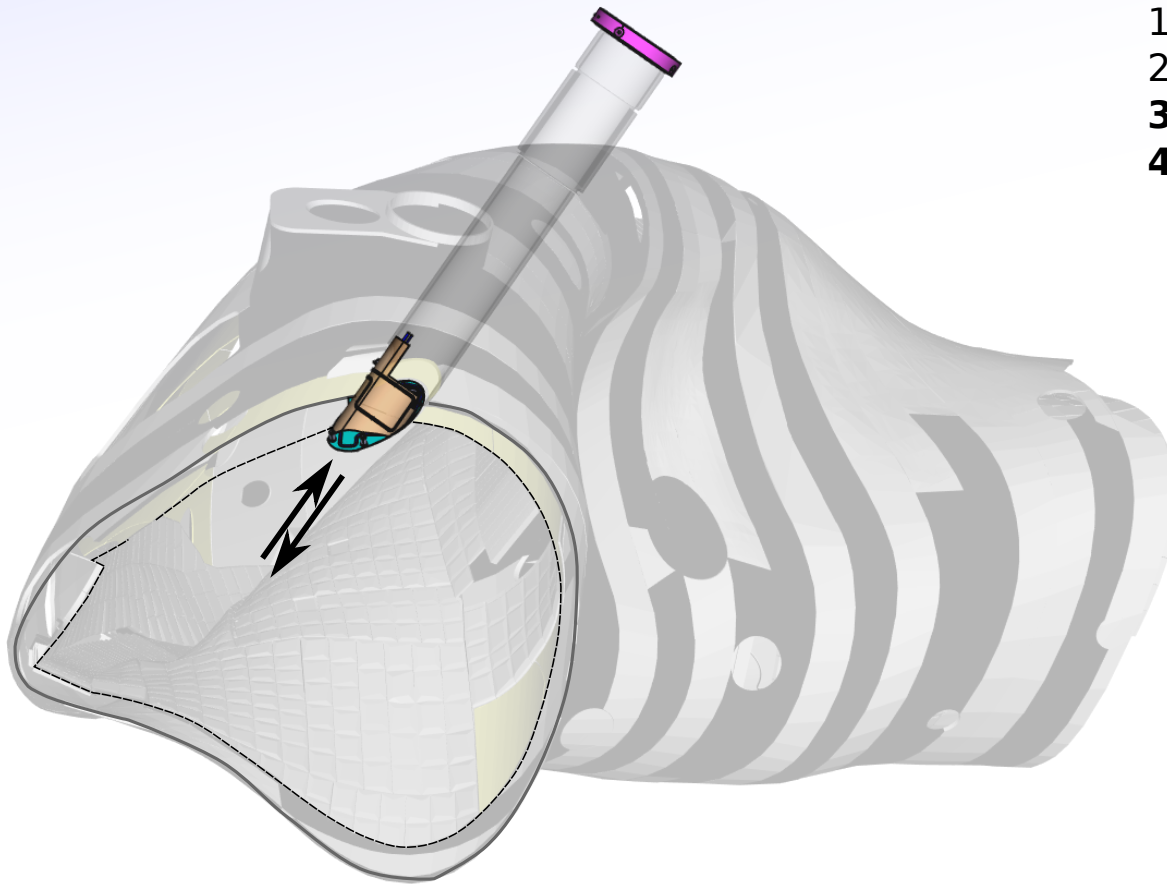

- 1) Install passring.
- 2) Bring port protection into vessel
- 3) Test install port protection.**
- 4) Remove port protection**

## AEM21 port protection - Installation

11 / 23  
[13]

- Installation in stages, due to length of pipes:

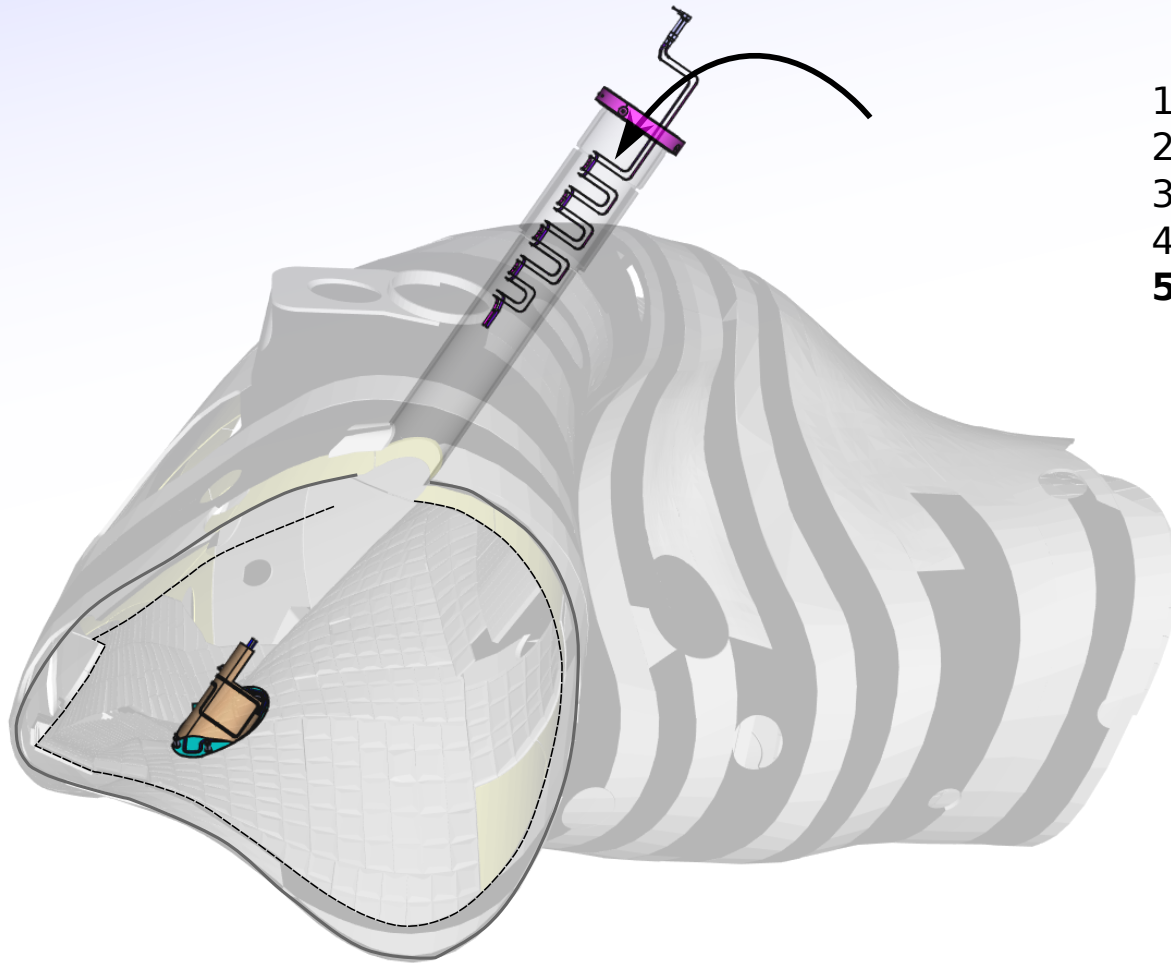

- 1) Install passring.
- 2) Bring port protection into vessel
- 3) Test install port protection.
- 4) Remove port protection
- 5) Bring pipes into vessel via port.**

# AEM21 port protection - Installation

12 / 23  
[14]

- Installation in stages, due to length of pipes:

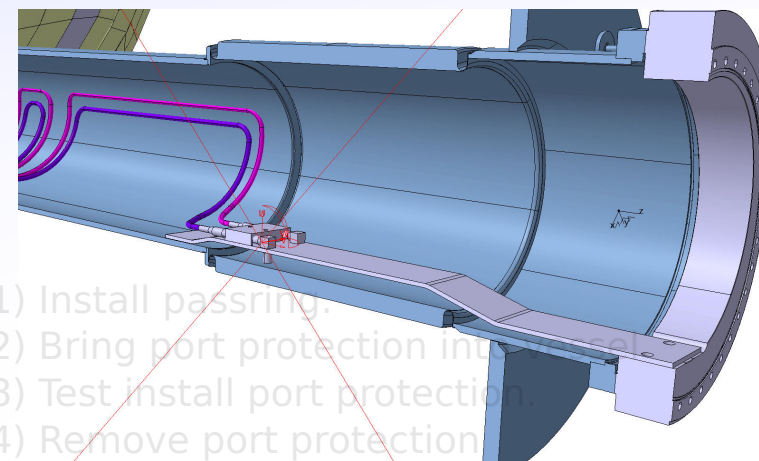
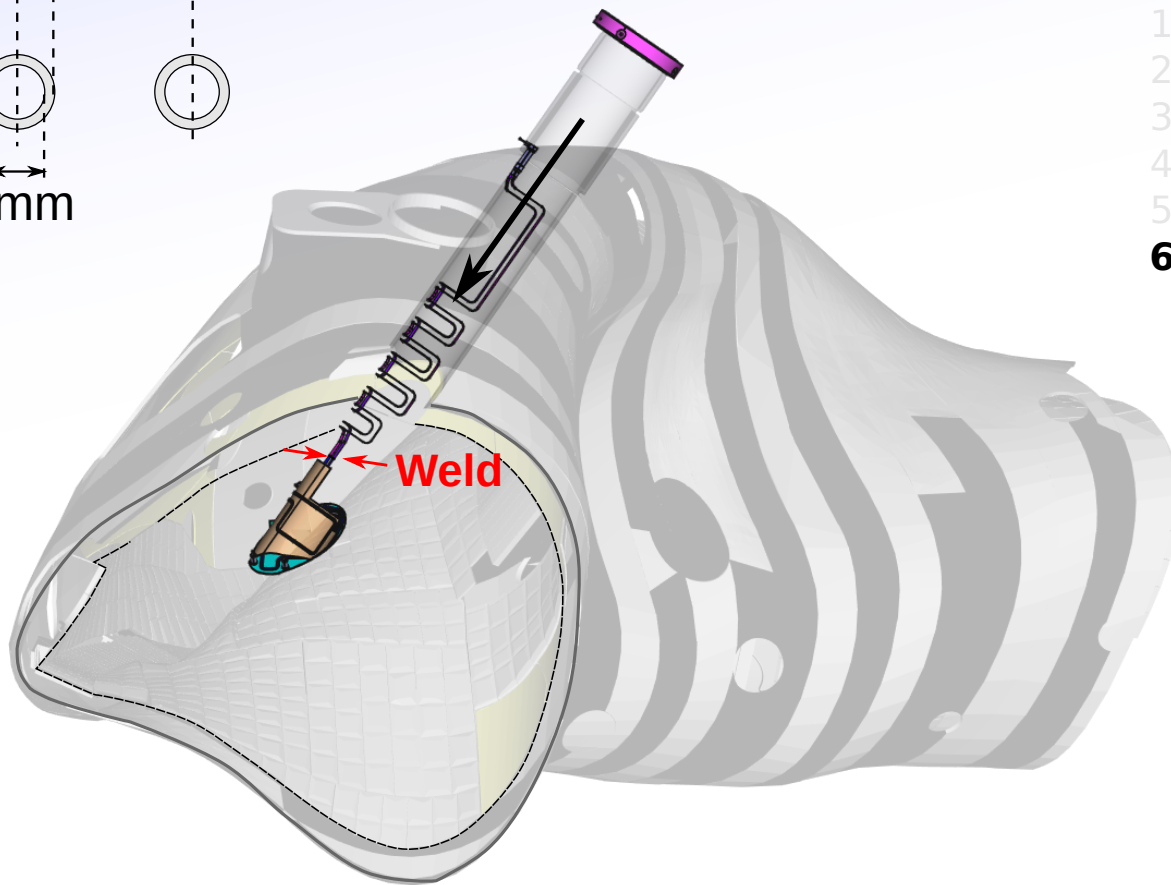
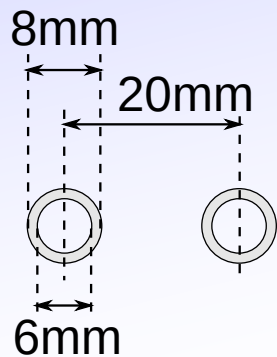

- 1) Install passing.
- 2) Bring port protection into vessel.
- 3) Test install port protection.
- 4) Remove port protection.
- 5) Bring pipes into vessel via port.
- 6) Weld pipes to port protection in vessel.**

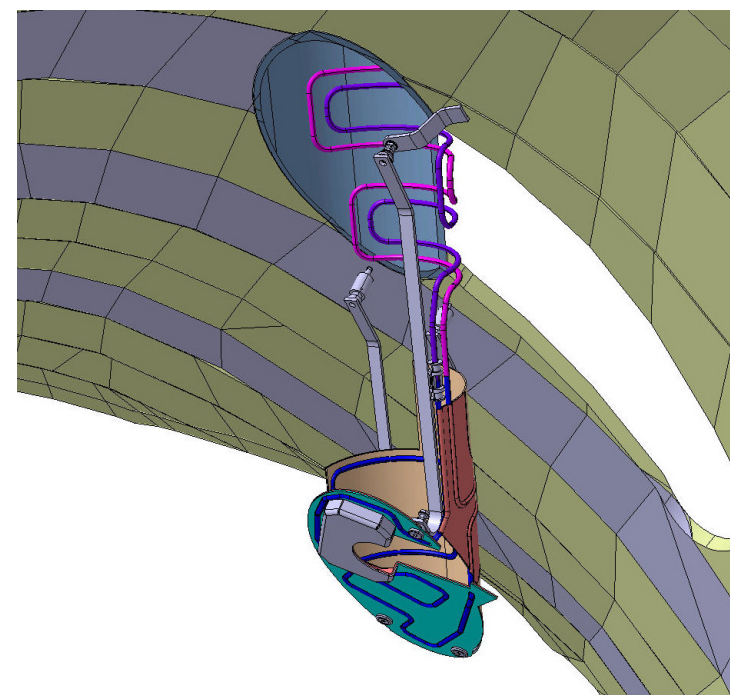

## AEM21 port protection - Installation

13 / 23  
[15]

- Installation in stages, due to length of pipes:

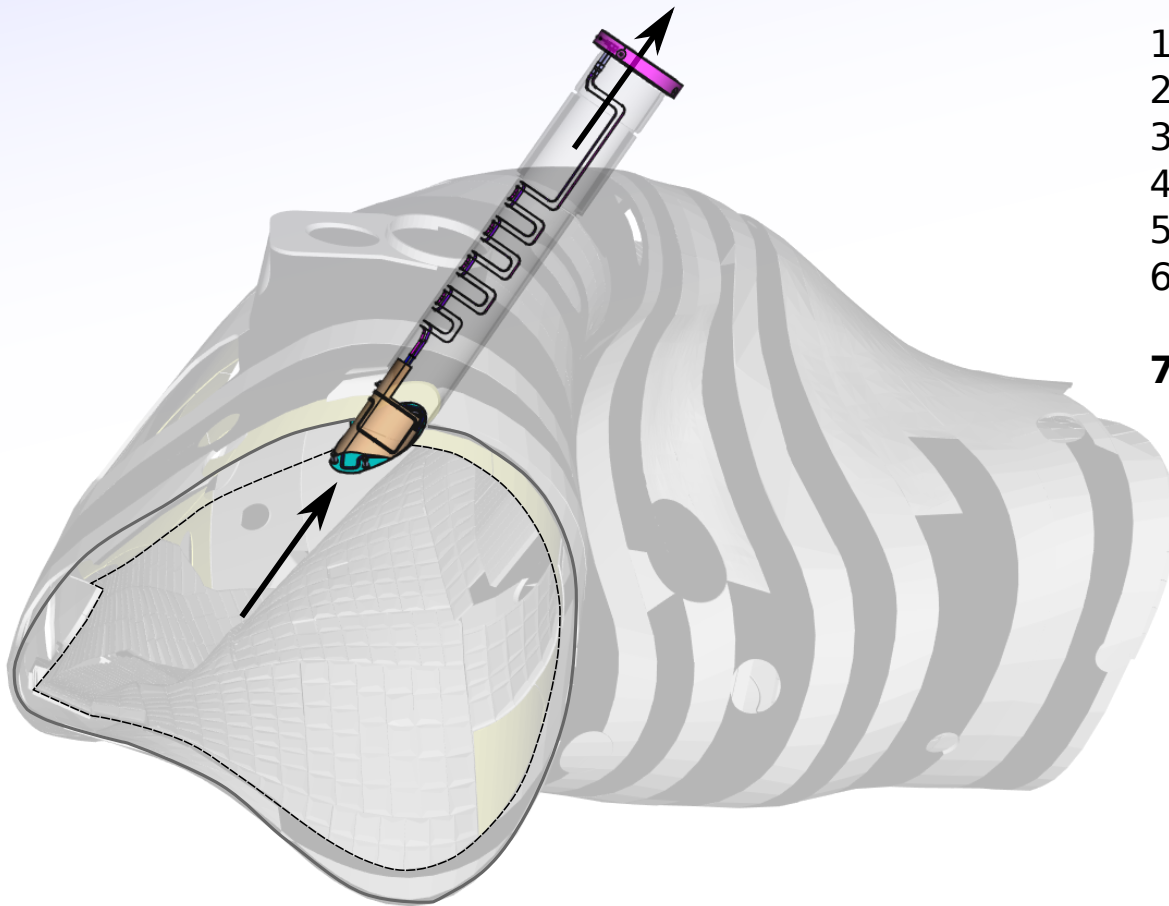

- 1) Install passring.
- 2) Bring port protection into vessel
- 3) Test install port protection.
- 4) Remove port protection
- 5) Bring pipes into vessel via port.
- 6) Weld pipes to port protection in vessel.
- 7) Install port protection.**



## AEM21 port protection - Installation

14 / 23  
[16]

- Installation in stages, due to length of pipes:

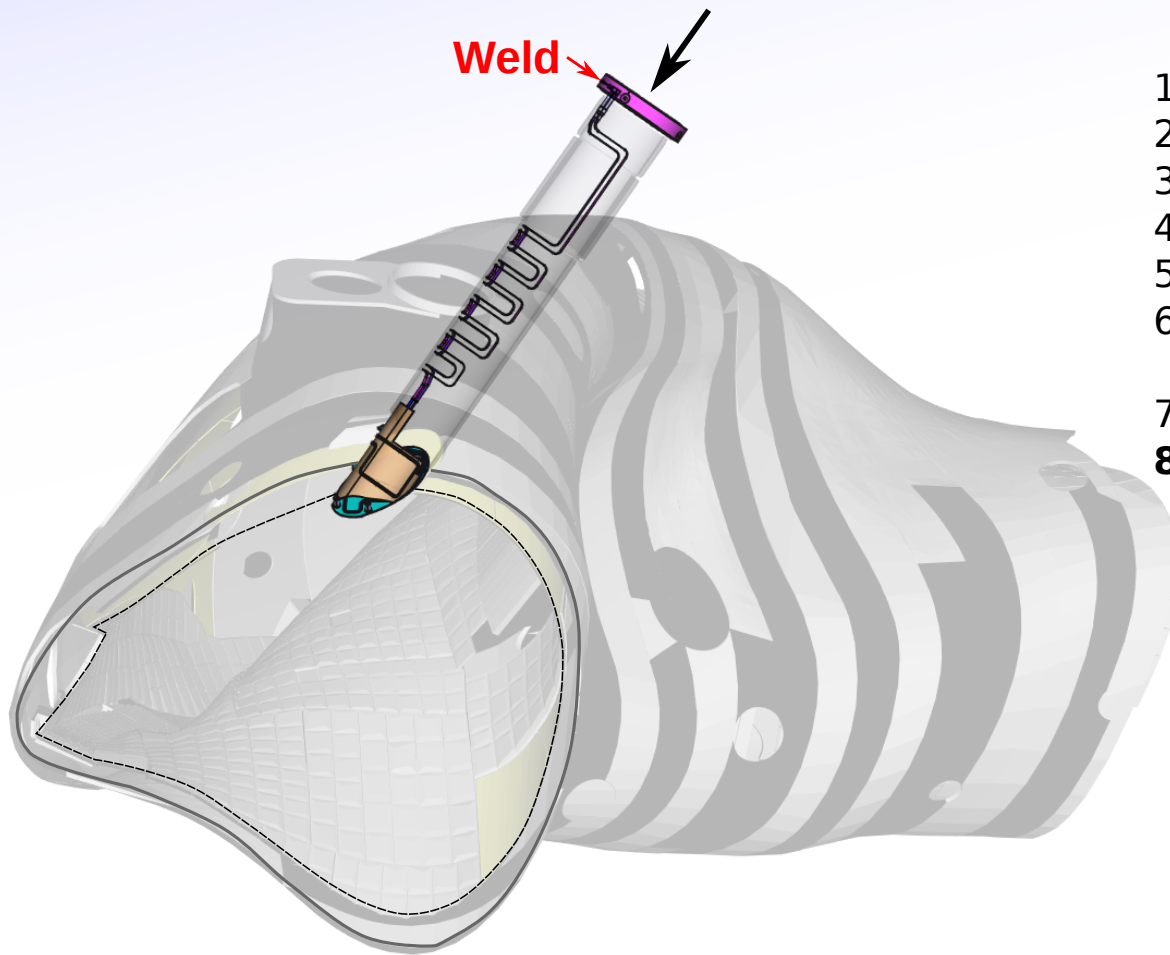

- 1) Install passring.
- 2) Bring port protection into vessel
- 3) Test install port protection.
- 4) Remove port protection
- 5) Bring pipes into vessel via port.
- 6) Weld pipes to port protection in vessel.
- 7) Install port protection.
- 8) Weld pipes to passring.**

# AEM21 port protection - pipes to passring

15 / 23  
[18]

Welding of pipes to passring:

- Weld inside pipe from outside of port due to limited space inside passring.  
(similar to AEM41 portliner)

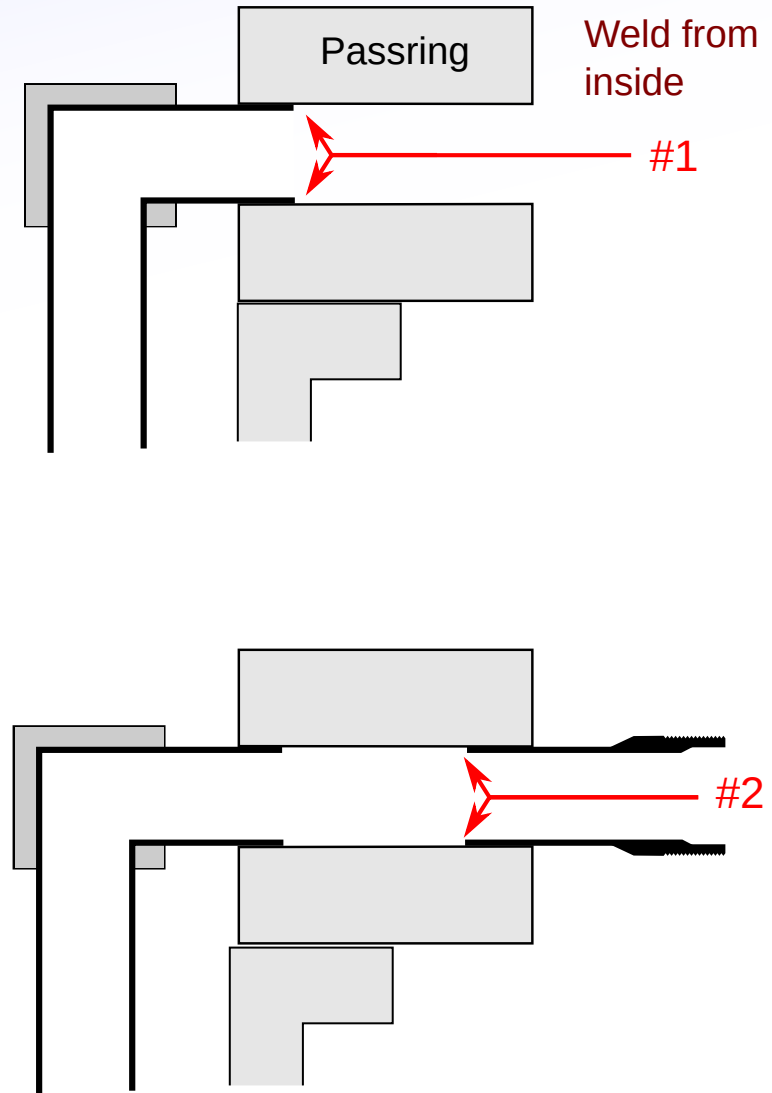
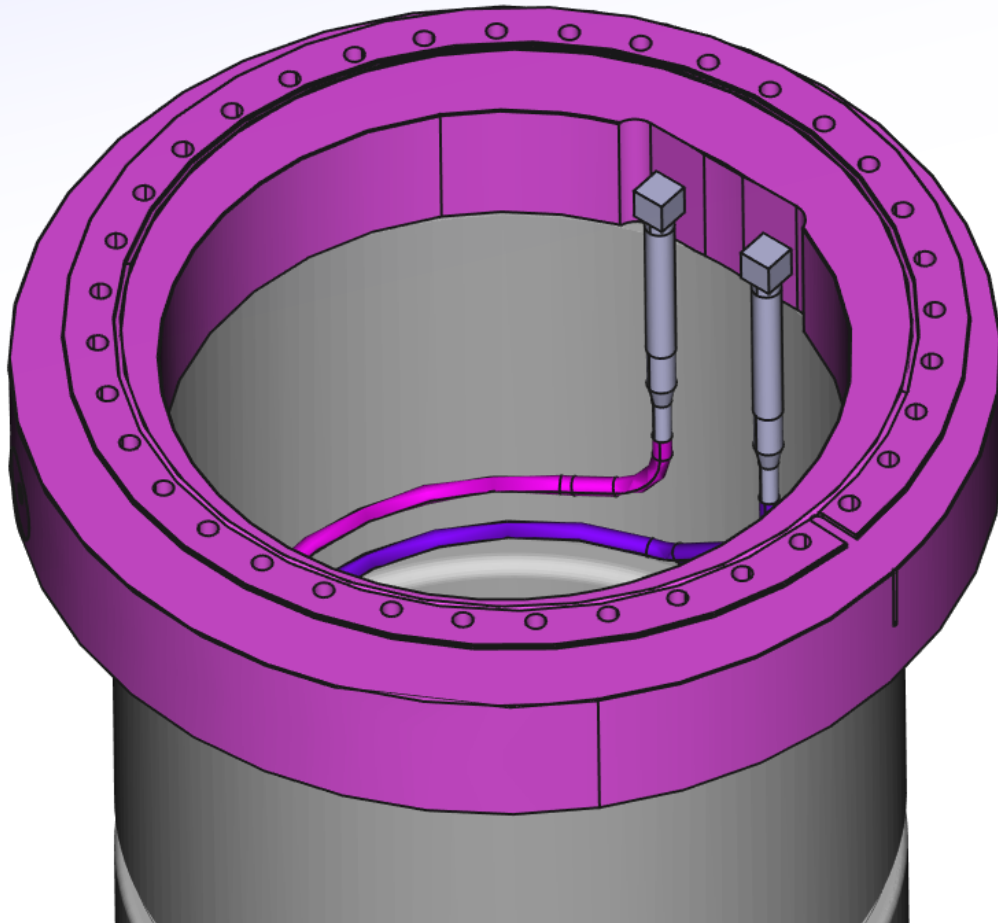

# AEM21 port protection - thermal analysis

16 / 23  
[30]

Thermal analysis of the port protection shows acceptable temperatures:

- Max 355°C on front plate, max 86°C on vessel [1-QSK-Y0006 by EN (M. Khokhlov)]
- Water flow rate and pressure drop OK and sufficient for cooling.

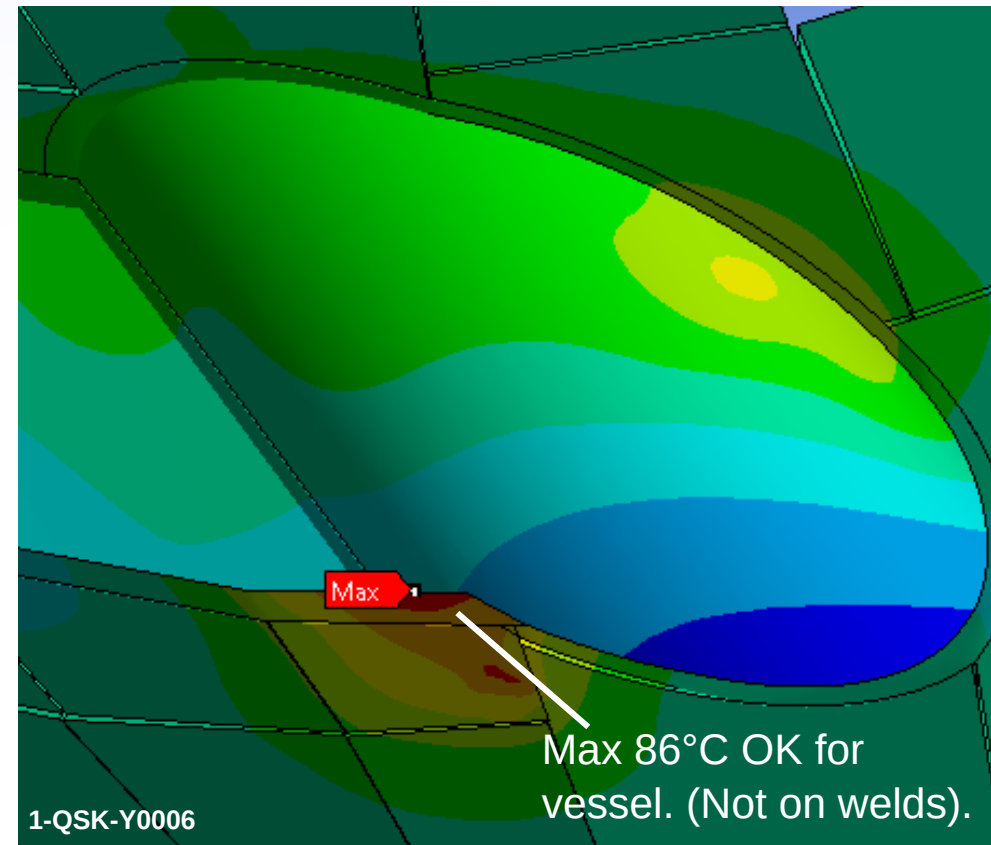
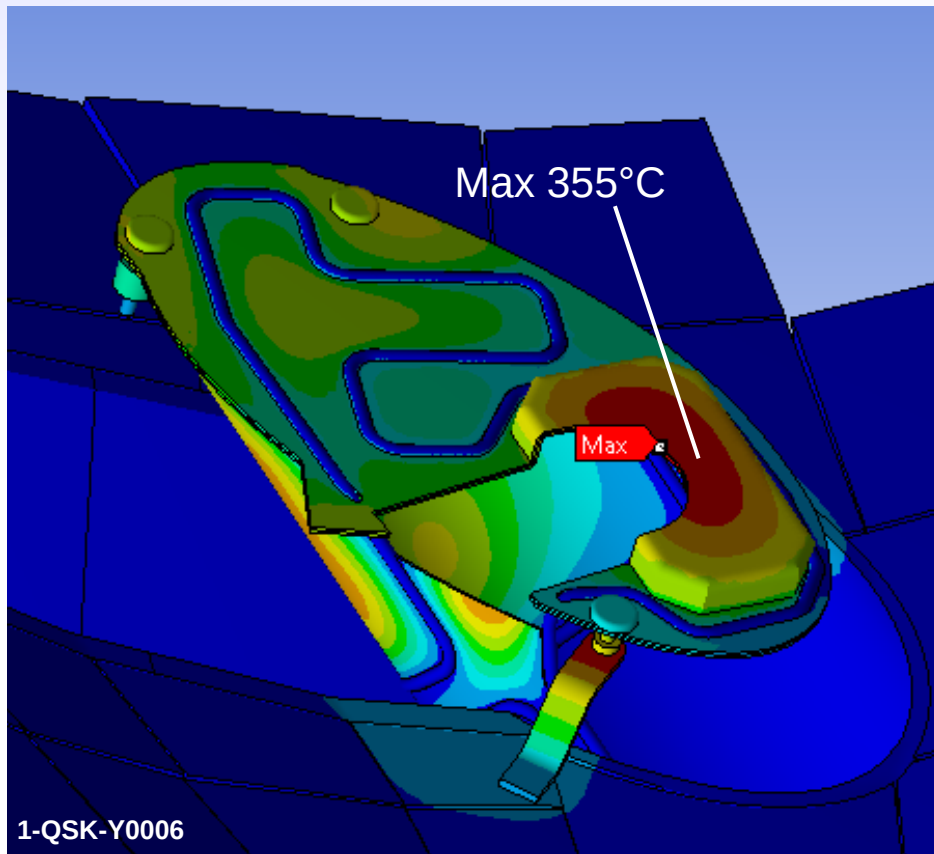

# AEM21 port protection - thermal analysis

Thermal analysis of the final port protection shows acceptable temperatures:

- Power loads calculated from  $100\text{kW/m}^{-1}$  at plasma boundary using ray tracing.
- 1800s or steady-state temperature evaluated by EN (M. Khokhlov).
- Radiative cooling ignored.
- Good conduction via copper plating assumed.
- No copper plating on rear shield assumed.  
(but it will be plated anyway --> even lower temperatures)

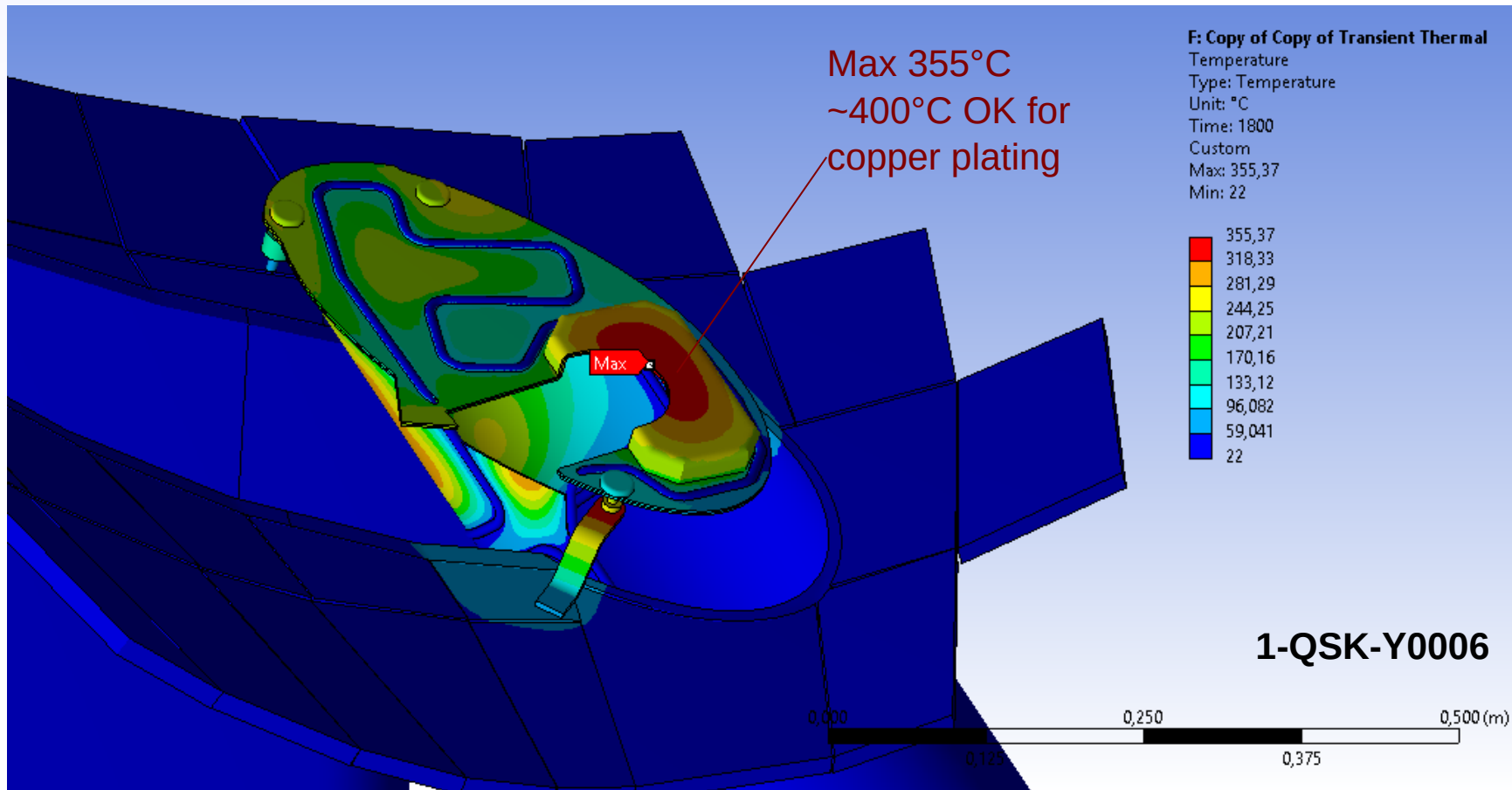

# AEM21 port protection - thermal analysis

- Max temperature of rear shield calculated as 311°C.
- This was calculated with no copper plating as we wanted to avoid it but it is required anyway to conduct the pipes to plate sufficiently. The real temperatures will therefore be far lower.

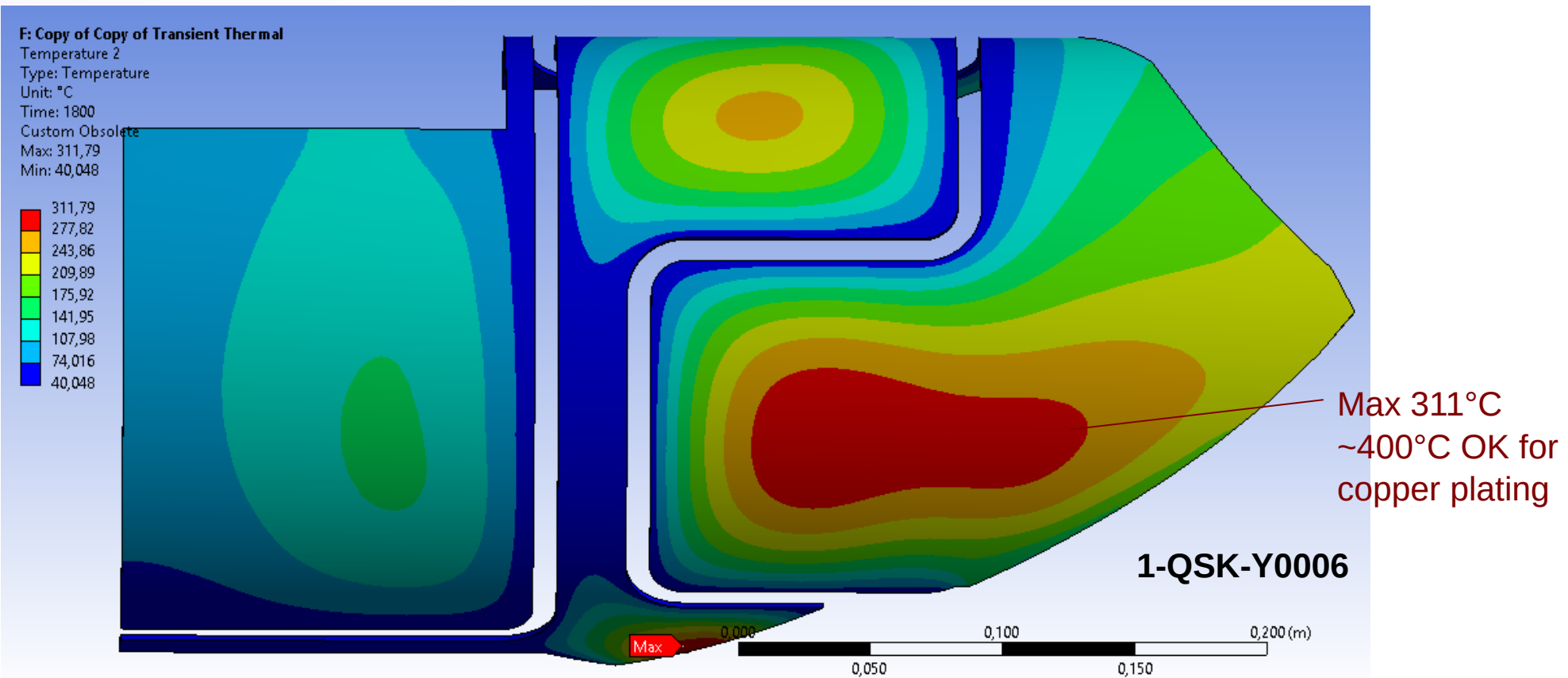



# AEM21 port protection - thermal analysis

- The mount arm and a small part of the vessel and port are exposed to the plasma.
- Mount arm can heat up to max 350°C - OK for stainless steel component.

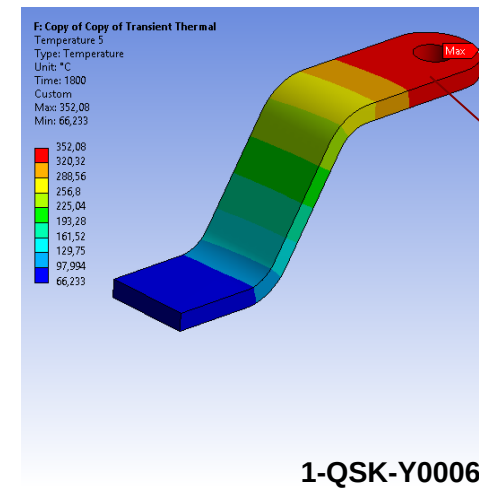
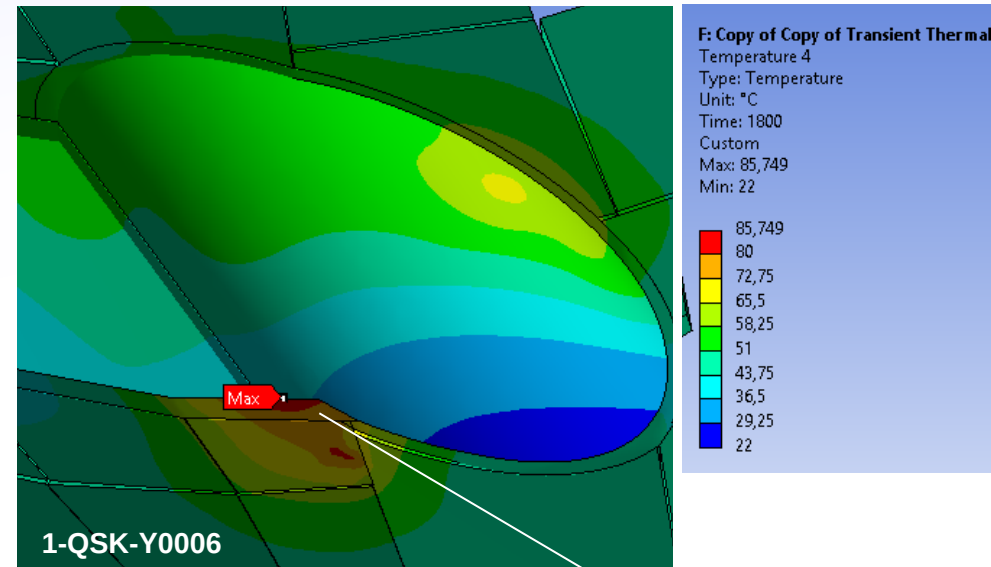
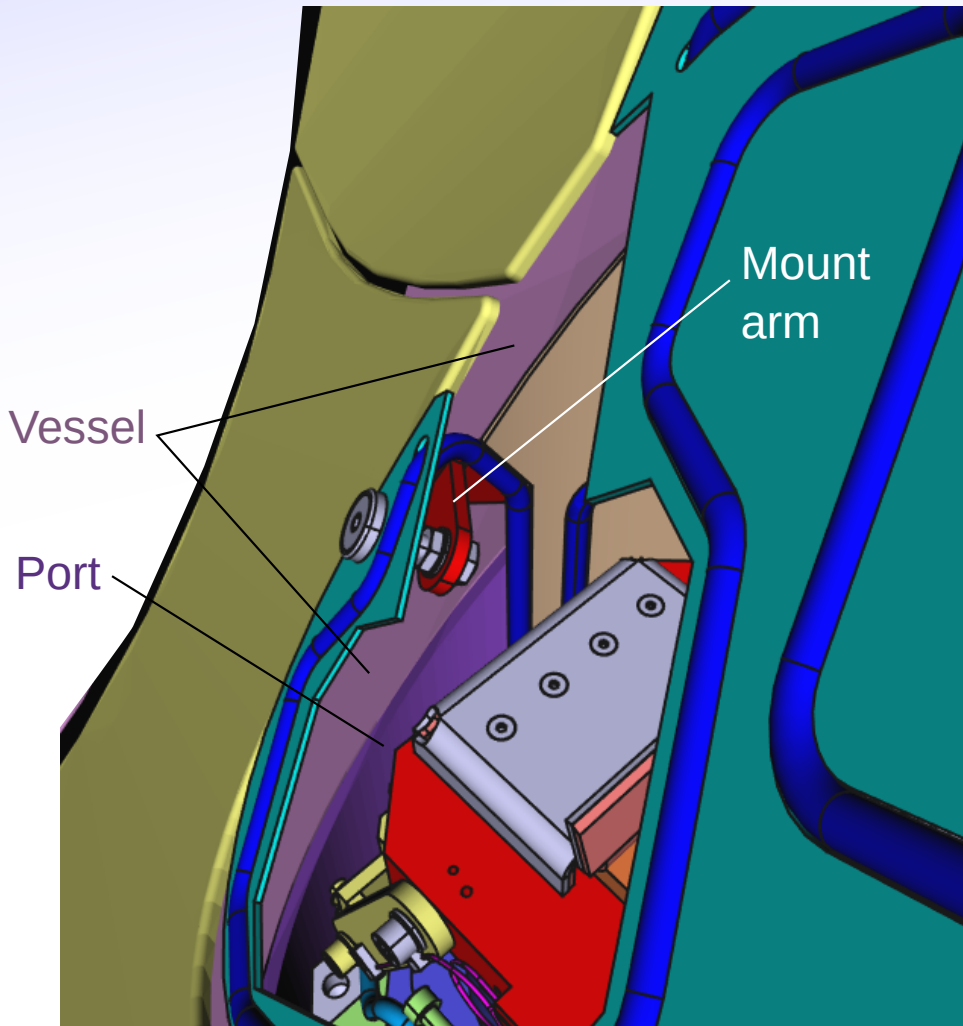

Max 85°C OK for vessel.  
(Not on welds).

Max 350°C OK for steel component.



## AEM21 port protection - flow rate

(1-QSK-~~20006~~,  
M. Khokhlov)<sup>[8]</sup>

- Due to the 7mm inner diameter (usually 11mm), the flow rate/pressure drop relation is more critical.

0.2 l/s = 9.2bar (> 6 bar limit)

0.1 l/s = 3 bar (< 6 bar limit)

At 0.1l/s the temperature rise due to the 5kW = 15°C. --> OK

## AEM21 port protection - Gaps

21 / 23  
[60]

Front panel is effectively a panel, which gaps are required to be  $< 10\text{mm}$  (1-AC-T0004).

- As-designed gaps meet this requirement.
- As-designed gaps used for thermal calculations --> tolerable loads on vessel and port walls.
- Panel is adjustable via mounts up to  $\pm 2\text{mm}$  adjustment in all directions.

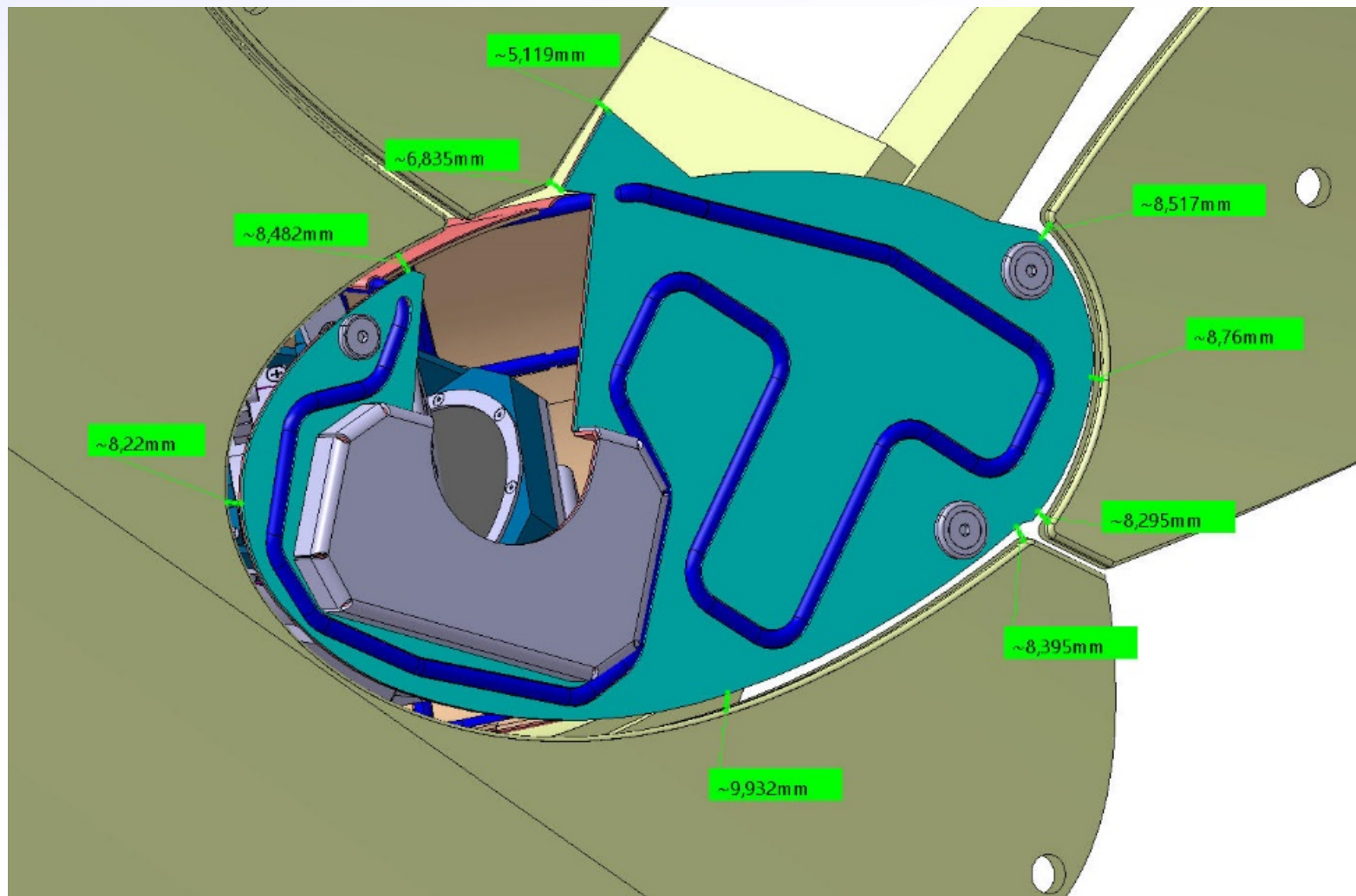



# AEM21 port protection - pipes to passring

22 / 23  
[71]

Sufficient space for welding pipes to passring:

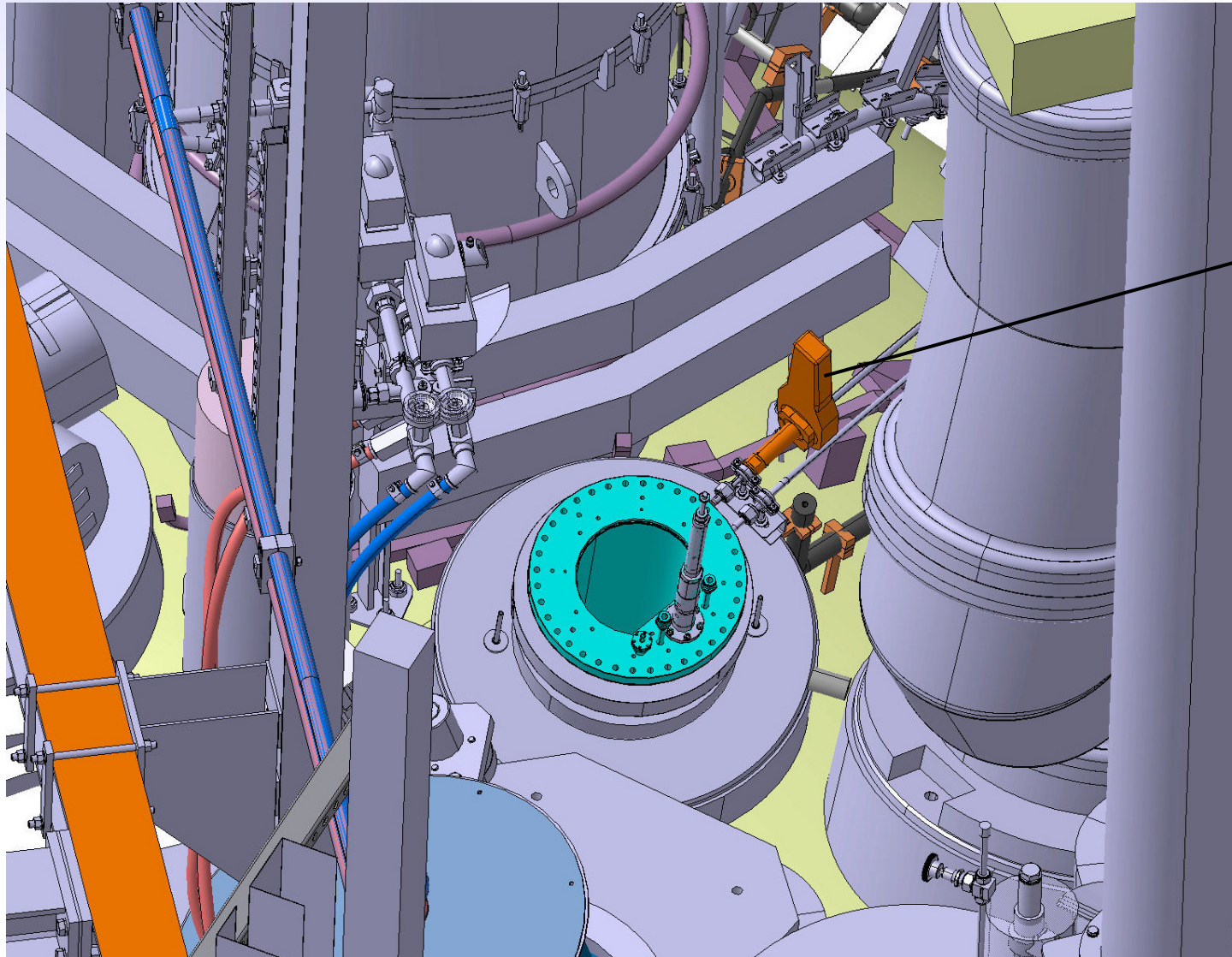

Innen-  
Orbitalschweißzange

# AEM21 port protection - Installation

Support devices for port protection and pipes during in-vessel welding:

